

**Areas & Volumes  
Conventional Questions**

1. [14-15 S.6 Mock Exam #14]

- (a) **Figure 4(a)** shows two similar right circular cones *A* and *B*, the base radius and height of cone *A* are 4 cm and 6 cm respectively. It is given that the ratio of volume of cone *A* to volume of cone *B* is 1 : 8. Two small cones with base radius 1 cm are cut off from the top of cones *A* and *B* respectively. Find the volume of the frustum after the small cone is cut off from the cone *B* in terms of  $\pi$ . (4 marks)

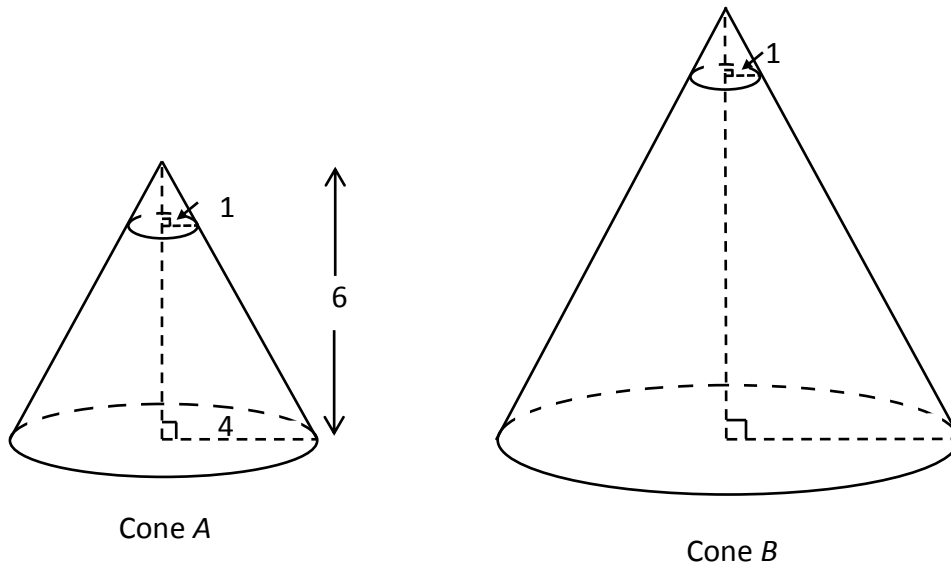

**Figure 4(a)**

- (b) A sand filter is formed by merging two frustums after the small cones are cut off. The bigger frustum is put on top and completely filled with sand. The sand filter is now placed on the horizontal ground as shown in **Figure 4(b)**. After the smaller frustum is fully filled with sand, Peter claims that the depth of the empty space in the bigger frustum is less than 0.5 cm. Do you agree? Explain your answer. (4 marks)

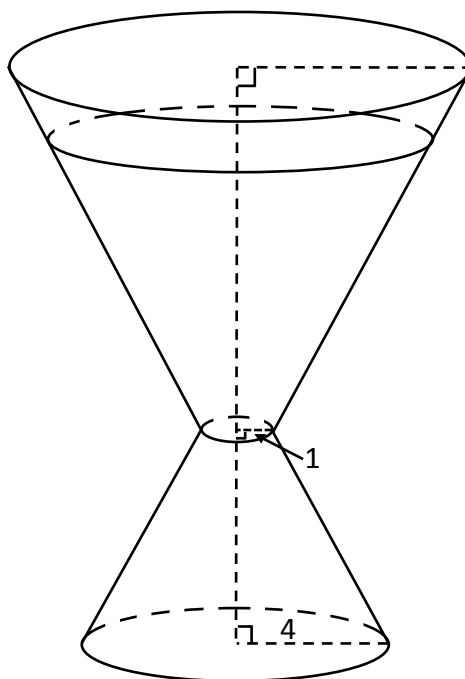

**Figure 4(b)**

2. [14-15 Standardized Test #8]

- (a) **Figure 4(a)** shows a frustum  $ABCD$  of a right circular cone  $VAB$ . The radii of the upper base and the lower base are 20 cm and 12 cm respectively. The slant height of the frustum is 11.6 cm. Find the volume of the frustum in terms of  $\pi$ . **(4 marks)**
- (b) **Figure 4(b)** is another frustum  $X$  which is similar to  $ABCD$ . If the slant height of frustum  $X$  is 5.8 cm. Find the volume of  $X$  in terms of  $\pi$ . **(2 marks)**

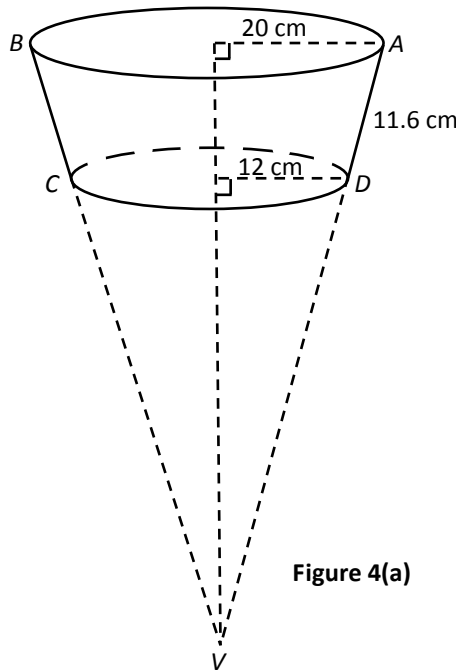

Figure 4(a)

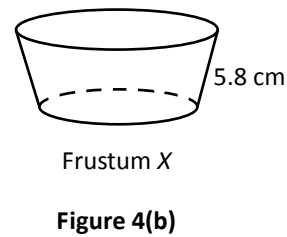

Figure 4(b)

- (c) Peter would like to make two new solids  $P$  and  $Q$  as shown in **Figure 4(c)**. He puts a right circular cone on top of each of the frustums  $ABCD$  and  $X$  where the base of each cone is the same as the upper base of the frustum. It is given that the height of two cones are the same. Peter claims that  $P$  and  $Q$  are similar. Do you agree? Explain your answer. **(2 marks)**

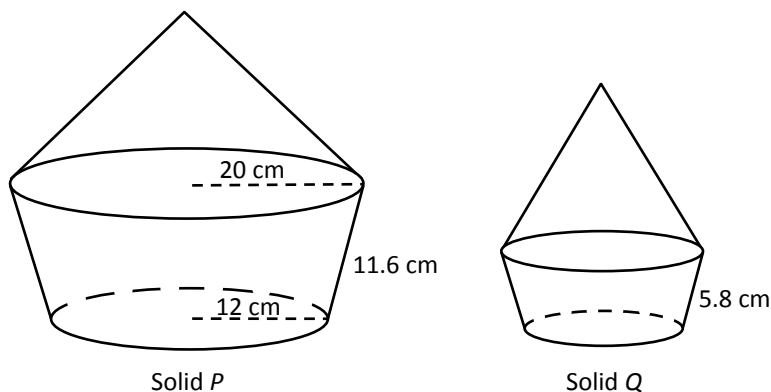

Figure 4(c)

3. [14-15 Final Exam #13]

Mary would like to sell jelly with two layers in snackathon, while the two layers are red and blue in color respectively. She is making a bigger glass for display, the glass is in a shape of an inverted right circular cone. The bottom layer is red in color with base radius 2 cm and height 6 cm, the second layer is blue in color with height 9 cm as shown in **Figure 7**.

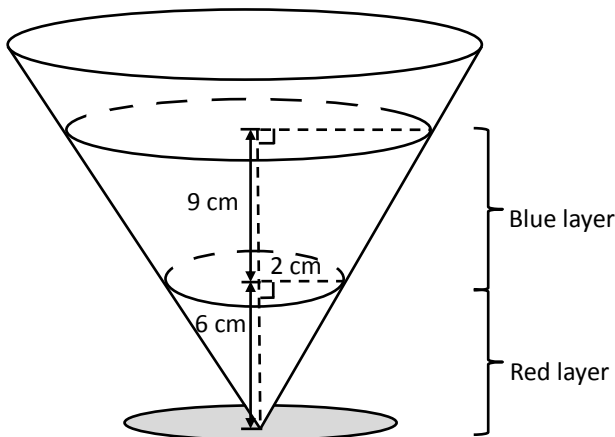

Figure 7

- (a) Find the volume of the jelly in red color in terms of  $\pi$ . (1 mark)
- (b) Find the volume of jelly in blue color in terms of  $\pi$ . (3 marks)
- (c) In snackathon, Mary will sell a smaller glass of jelly which is similar to the one in **Figure 7** and she plans to sell 40 glasses. After finishing the red layer, the base radius of the red layer is 1 cm. Mary is going to make the blue layer on top of the red layer. She needs to prepare the mixture in a hemispherical bowl with internal radius of  $x$  cm before she pours the blue mixture to each glass. Mary claims that using a bowl with internal radius of 9.5 cm is enough to prepare for the mixture for all glasses. Do you agree? Explain your answer. (3 marks)

4. [15-16 Mid-year Exam #7]

In **Figure 4**,  $VABCD$  is a right square pyramid. It is given that  $VO = 3AB$  and the volume of pyramid  $VABCD$  is  $512 \text{ cm}^3$ .

- (a) Find the length of  $AB$ . (2 marks)
- (b) Find the total surface area. (2 marks)

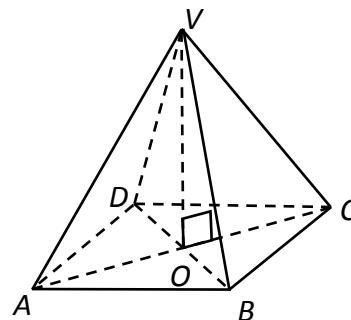

Figure 4

5. [15-16 Standardized Test #4]

Figure 3 shows a solid made by cutting off a right circular cone and a hemisphere from a cylinder of height 20 cm. The base radius and the height of the removed circular cone are  $r$  cm and 8 cm respectively. The radius of the hemisphere is  $r$  cm. The total volumes of the two removed parts are one-third of the volume of the original cylinder.

- (a) Find  $r$ . (3 marks)
- (b) Find the total surface area of the solid in terms of  $\pi$ . (3 marks)

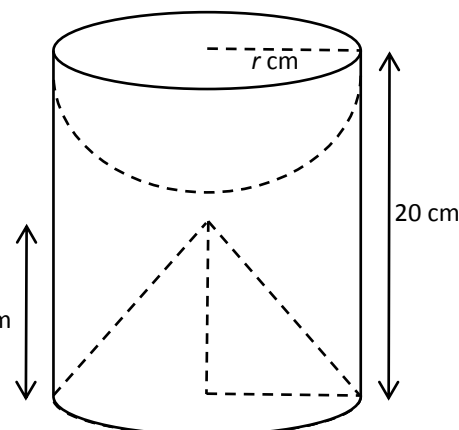
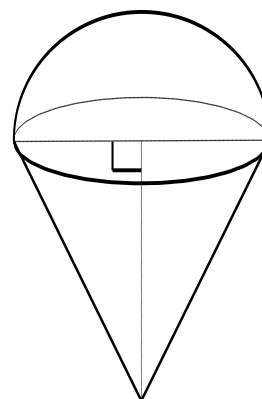

Figure 3

6. [15-16 Final Exam #15]

An ice-cream shop has prepared a gift whose shape consists of a hemisphere on top of an inverted right circular cone as shown in Figure 8. The base diameter of the cone is 8 cm and the curved surface area of the cone is  $\sqrt{6656\pi}$  cm<sup>2</sup>.

- (a) Find, in terms of  $\pi$ , the volume of the hemisphere. (2 marks)
- (b) Find the height of the cone. (2 marks)
- (c) The shopkeeper wants to make a bigger version of the gift which is similar to the original one. If the total surface area of the gift is increased by 4%, find the percentage change in the height of the cone. (2 marks)



7. [15-16 Final Exam #20]

Trinity uses clay to make a solid cone as shown in Figure 12(a). Later, her sister removes some clay in it to make a cylindrical hole inside as shown in Figure 12(b). It is given that the radius of the cylindrical hole is  $r$ . If the base radius of the cone is 4 times the base radius of the cylindrical hole, find the percentage change in the volumes. (3 marks)

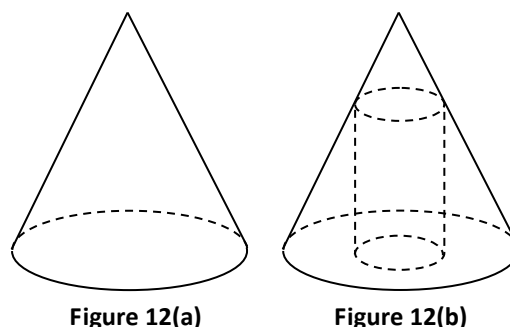

Figure 12(a)

Figure 12(b)

8. [16-17 Standardized Test #4]

In Figure 3(a), solid X is formed by fixing a right circular cone of base radius 3 cm and height 8 cm onto a hemisphere with the same radius.

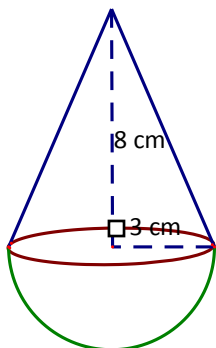

Figure 3(a): Solid X

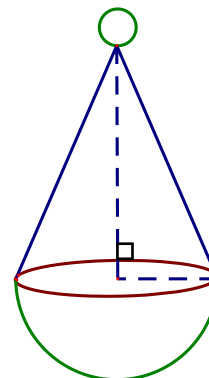

Figure 3(b): Solid X'

- (a) Find the volume of solid X. (3 marks)
- (b) Another solid Y is similar to X such that the total surface area of solid X : the total surface area of solid Y = 9 : 16. Find the volume of solid Y. (2 marks)
- (c) In Figure 3(b), solid X' is formed by fixing a sphere of diameter 2 cm on the tip of solid X. Another solid Y' is formed by fixing a sphere of diameter 3 cm on the tip of solid Y. Are solid X' and solid Y' similar? Explain your answer. (2 marks)

9. [16-17 Mid-year Exam #11]

Figure 4(a) shows a rectangular pyramid VABCD. It is made of sand and V is vertically above D. VAB, VBC, VCD and VDA are right-angled triangles. It is given that AB = 12 cm, BC = 8 cm and VD = 16 cm.

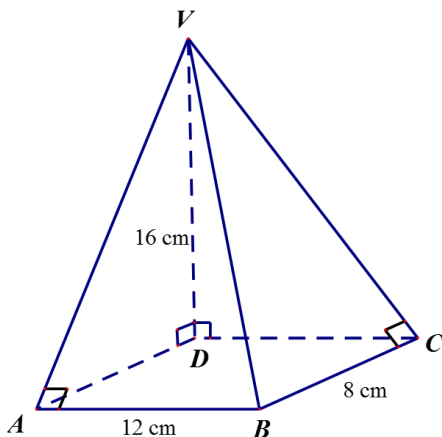

Figure 4(a)

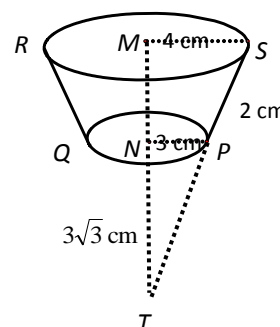
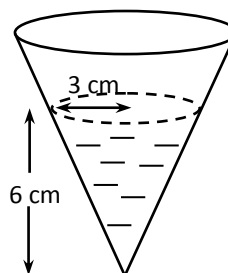

Figure 4(b)

- (a) (i) Find  $V_A$  and  $V_C$ . (1 mark)
- (ii) Find the total surface area of the pyramid. (2 marks)
- (b) **Figure 4(b)** shows a cup  $PQRS$  in a shape of a conical frustum with lower base radius  $NP$  3 cm and upper base radius  $MS$  4 cm. Its slant height  $PS$  is 2 cm and  $NT$  is  $3\sqrt{3}$  cm. Show that the capacity of the cup is  $\frac{37\sqrt{3}}{3}\pi$  cm<sup>3</sup>. (2 marks)

10. [16-17 Final Exam #17]

**Figure 7** shows a right circular conical container, which holds some water in it. It is known that the depth of the water is 6 cm and the radius of the circular surface of the water is 3 cm.



- (a) Find the wet surface area of the container. (2 marks)
- (b) If a marble is totally submerged in the water and the wet surface area of the container increases by 56.25%, find the volume of the marble. (2 marks)

(2 marks) Figure 7

11. [17-18 Mid-year Exam #8]

**Figure 4** shows a pyramid  $VABCD$  with a rectangular base. It is given that  $AB = 12$  cm,  $BC = 9$  cm and the height of the pyramid is 5 cm.

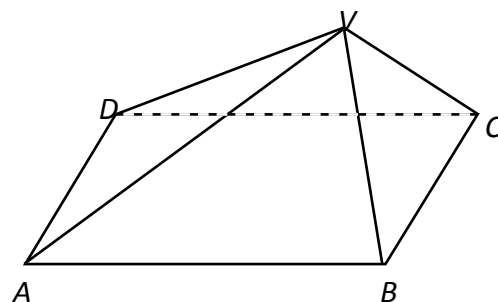

- (a) Find the volume of  $VABCD$ . (2 marks)
- (b) If  $AB$  is increased by 20%,  $BC$  remains unchanged, and the height of the pyramid is reduced by 30%, find the percentage decrease in its volume. (3 marks)

Figure 4

12. [17-18 Mid-year Exam #9]

In **Figure 5**, it shows a right pyramid  $A$  with height  $VO$ . Its base  $PQRS$  is a square with sides 4 cm. The volume of the pyramid is  $\frac{32\sqrt{7}}{3}$  cm<sup>3</sup>. It is given that  $M$  and  $N$  are the mid-points of  $PQ$  and  $QR$  respectively.

- (a) Find the height  $VO$ . Keep your answer in surd form. (2 marks)
- (b) Find the length of the slant edge of the pyramid. (3 marks)
- (c) There is another right pyramid  $B$  with slant edge 20% longer than that of right pyramid  $A$ , and its base is a square with sides 4 cm. Kelly claimed that the area of lateral faces of right pyramid  $B$  is larger than that of right pyramid  $A$  by more than 22.5%. Do you agree with her claim? Explain your answer. (3 marks)

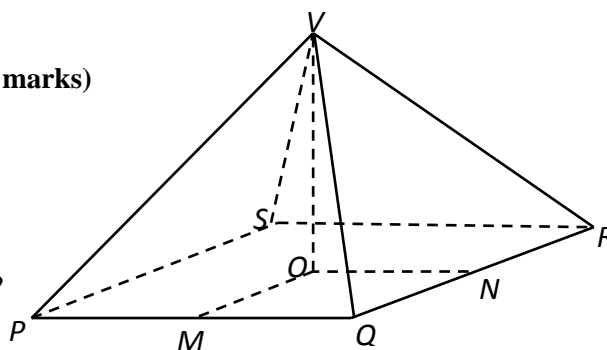

Figure

13. [17-18 Standardized Test #6]

Figure 2a shows a solid metal cuboid. It is melted and recast into two similar solid right pyramids with square bases as shown in Figure 2b. The ratio of the base area of the smaller pyramid  $ABCDE$  to the base area of the larger pyramid  $FGHIJ$  is 4 : 9.

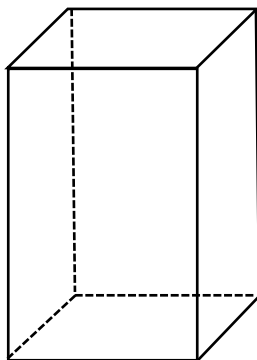

Figure 2a

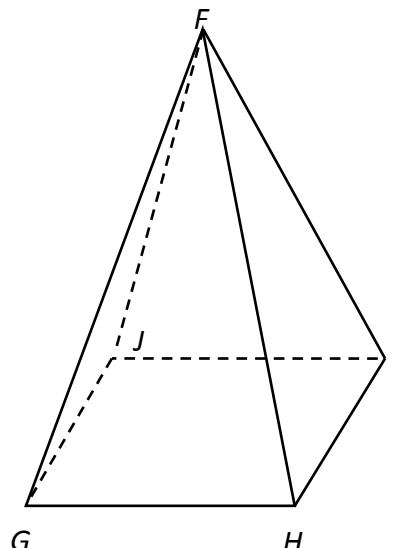
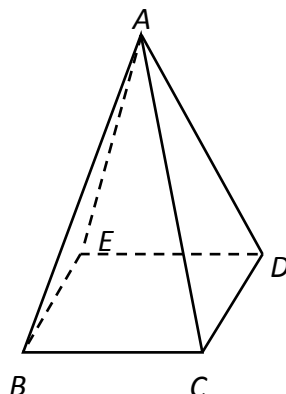

Figure 2b

- (a) (i) Write down the ratio of  $BC : GH$ . (1 mark)
- (ii) It is given that the volume of the larger pyramid  $FGHIJ$  is  $V \text{ cm}^3$ . Express the volume of the smaller pyramid in terms of  $V$ . (1 mark)
  
- (b) (i) It is given that the base area and the height of the cuboid is  $42 \text{ cm}^2$  and  $15 \text{ cm}$  respectively.  
 Find the volume  $V$  of the larger pyramid. (2 marks)
- (ii) If the height of the larger pyramid is  $18 \text{ cm}$ , find the side length of the base of the larger pyramid. (2 marks)
- (iii) Find the total surface area of the smaller pyramid. (2 marks)

14. [17-18 Final Exam #9]

It is given that  $h \text{ cm}$  and  $H \text{ cm}$  are the original height and the new height of a cylinder. If the original radius  $r \text{ cm}$  of the cylinder is increased by 25%, find the percentage change in the height of the cylinder if its volume remains unchanged. (3 marks)

15. [17-18 Final Exam #14]

- (a) An inverted right circular conical vessel of base radius 14 cm and height 41 cm is fully filled with water. Find the volume of water in the vessel in terms of  $\pi$ . (2 marks)
- (b) Figure 5 shows a frustum container of upper base radius 15 cm, lower base radius 13 cm and height 14 cm. Find the volume of the container.
- (c) The water in the vessel in (a) is now poured into the container. If 6 solid metal spheres of radius  $r$  cm is then put into the container and the spheres are totally immersed in the water. By setting an inequality, find the maximum length of radius  $r$  cm, correct to 3 significant figures, such that the water will not overflow.

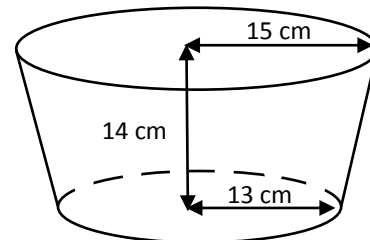

Figure 5

16. [18-19 Mid-year Exam #9]

Figure 4 shows a right pyramid  $VABCD$  with height 15 cm and a square base of side  $y$  cm. Its volume is  $1280 \text{ cm}^3$ .

- (a) (i) Find the value of  $y$ . (2 marks)
- (ii) Find the height of  $\triangle VAB$  with reference to the base  $AB$ . (1 mark)
- (b) Find the total surface area of the pyramid. (2 marks)

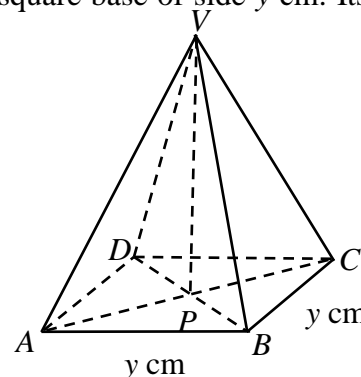

Figure 4

17. [18-19 S Test 2 #3]

In Figure 3,  $VABCD$  is a right pyramid with a rectangular base.  $VE$  is the height of the pyramid.

- (i) Name the projection of line  $VA$  on plane  $ABCD$ .
- (ii) Name the angle between line  $VA$  and plane  $ABCD$ . (1 mark)
- (a) If  $M$  is a point on  $BC$  and  $\angle VME$  is the angle between planes  $VBC$  and  $ABCD$ , what is the geometric relationship between  $M$  and  $BC$ ? (1 mark)

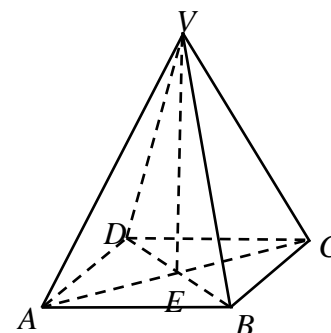
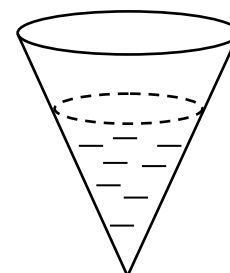

Figure 3



18. [18-19 S Test 2 #5]

In **Figure 4**, water of volume  $9\pi \text{ cm}^3$  is poured into an inverted right circular conical vessel. If the depth of water is the same as the radius of the water surface, find



**Figure 4**

- (a) (i) the depth of water, and
- (ii) the wet surface area of the vessel. (4 marks)

- (b) Amy claims that if an extra  $54\pi \text{ cm}^3$  of water is poured into the vessel and the water does not overflow, the percentage increase in the wet surface area of the vessel is less than 270%. Do you agree? Explain your answer. (2 marks)

19. [18-19 Final Exam #8]

A sector of area  $500\pi \text{ cm}^2$  and radius 25 cm, as shown in **Figure 2(a)**, is folded to form a right circular cone as shown in **Figure 2(b)**.

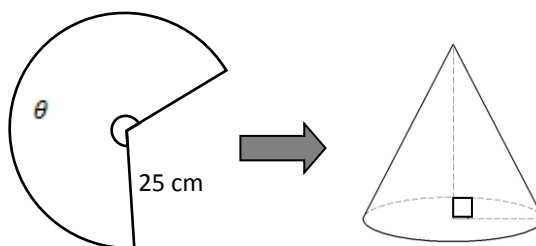

**Figure 2(a)**

**Figure 2(b)**

- (a) Find  $\theta$ . (1 mark)
- (b) (i) Find the base radius of the cone in **Figure 2(b)**. (2 marks)
- (ii) Find the volume of the cone in **Figure 2(b)**. (2 marks)